

HARMONIC  
DRIVE  
SYSTEMS

INC  
TOKYO JAPAN

# ENGINEERING SPECIFICATION

## Specifications of FHA-17C-E-SP with US type 14-Wires Encoder

Dec-24-2004

APPD	CHKD	BY

REV	DATE	DESCRIPTION	BY	CHKD	APPD	CLASS	SPEC NO.
							B2N1631
						SHEET NO.	1 OF 5

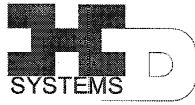

# ENGINEERING SPECIFICATION

1. Specifications in this document should be applied for the following FHA-17C-US-E-SP series.

1) FHA-17C-\*\*\*-US250-E-SP

2. Actuator

Table 1 show main specifications of the FHA-17C-E-SP with 14-wires encoder. Another specifications are same as that of standard actuator

Table 1 Specifications of FHA-17C

Ambient temperature (operation):0~40°C

Enclosure: Totally closed, self-cooling  
(IP44 equivalent)

Ambient temperature (storage):-20~60°C

Vibration:24.5m/s<sup>2</sup>

Relative humidity:20~80%RH(no condensation)

Shock resistance:294m/s<sup>2</sup>

Lubricant : Harmonic grease SK-1A<sup>3)</sup>

Item	Type Ratio	FHA-17C		
		50	100	160
Maximum torque	N·m	39	57	64
Maximum speed	r/min	96	48	30
Maximum current	A	30	22	16
Torque constant <sup>1)</sup>	N·m/A	1.5	3.0	4.8
Voltage constant	V/(r/min)	0.17	0.34	0.54
Moment of inertia	kg·m <sup>2</sup>	0.17	0.67	1.7
Continuous current	A	11	11	7.7
Continuous torque <sup>2)</sup>	N·m	11	24	24
Allowable radial load	kN	2.9		
Allowable axial load	kN	9.8		
Allowable torsional moment	N·m	188		
Moment stiffness	N·m/rad	2.2×10 <sup>5</sup>		
Unidirectional positioning accuracy	Arc-sec.	60	40	40
Resolution	p/rev	500,000	1,000,000	1,600,000
Mass	kg	2.5		

note 1) Torque constant is specified considering an efficiency of gear.

note 2) Continuous torque is determined when continuous current is given using HDSI driver.

note 3) If another grease is used, quality assurance test has to be done.

						CLASS	SPEC NO.
							B2N1631
REV	DATE	DESCRIPTION	BY	CHKD	APPD	SHEET NO.	2 OF 5



### 3. Motor

Motor specifications shown in Table 2

Table 2

Item	Type	FHA-17C
Input supply voltage		DC24V
Maximum speed	r/min	4800
Maximum torque <sup>1)</sup>	N · m	0.87 or more
Voltage constant	V/(rad/s)	0.032
Moment of inertia	$\times 10^{-4}$ kg · m <sup>2</sup>	0.55
Phase resistance (at 20°C)	$\Omega$	0.07
Phase inductance	mH	0.03
Number of paired poles		6
Insulation class		F
Voltage strength		AC500V/1min
Insulation resistance		100M $\Omega$ or more (by DC500V insulation tester)
Phase sequence		U→V→W (with CW rotation facing encoder end)

note 1) Maximum torque is determined when the current is 110% of theoretical value.

### 4. Encoder

#### 4-1 Main specifications

Main specifications shown in Table 3

Table 3

Item	Unit	Specification
Type		Incremental, Rectangular wave, 14-wires
Output signal		A, B, Z, U, V, W
Number of pulse	A,B	P/R 2500
	U,V,W	P/R 6
	Z	P/R 1
Power supply voltage	V	+5DC $\pm$ 5%
Current consumption <sup>1)</sup>	mA	350 max.
Output circuit form		Line driver (equivalent to AM26LS31C)
Maximum response frequency	kHz	200

note 1) When R1 resistor shown in Fig. 3 below

						CLASS	SPEC NO.
							B2N1631
REV	DATE	DESCRIPTION	BY	CHKD	APPD	SHEET NO.	3 OF 5

### 4-2. Signal waveform

Fig. 1 shows A, B and Z signal and relationship with U signal with CW rotation facing the encoder end.

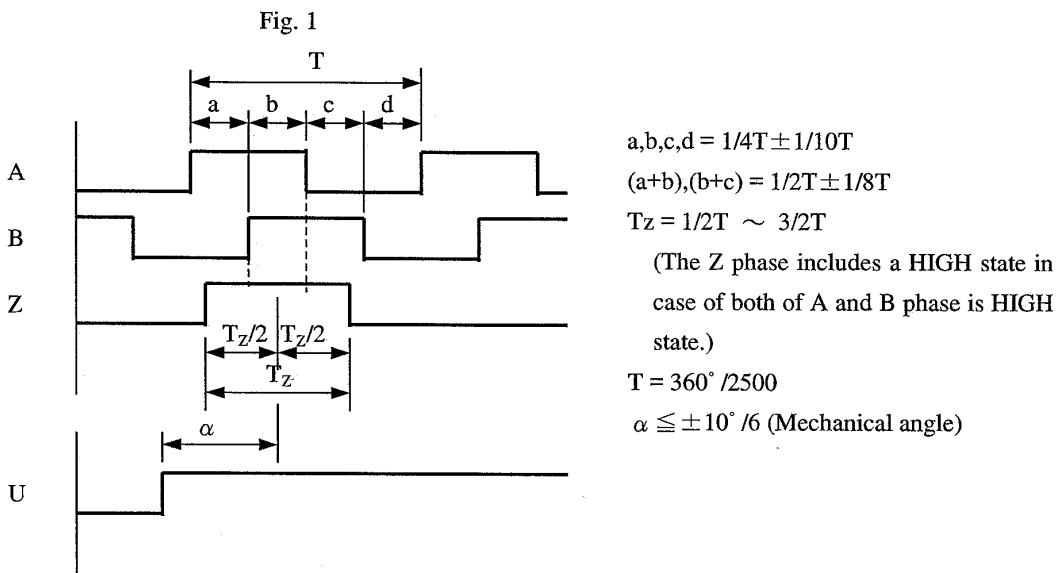
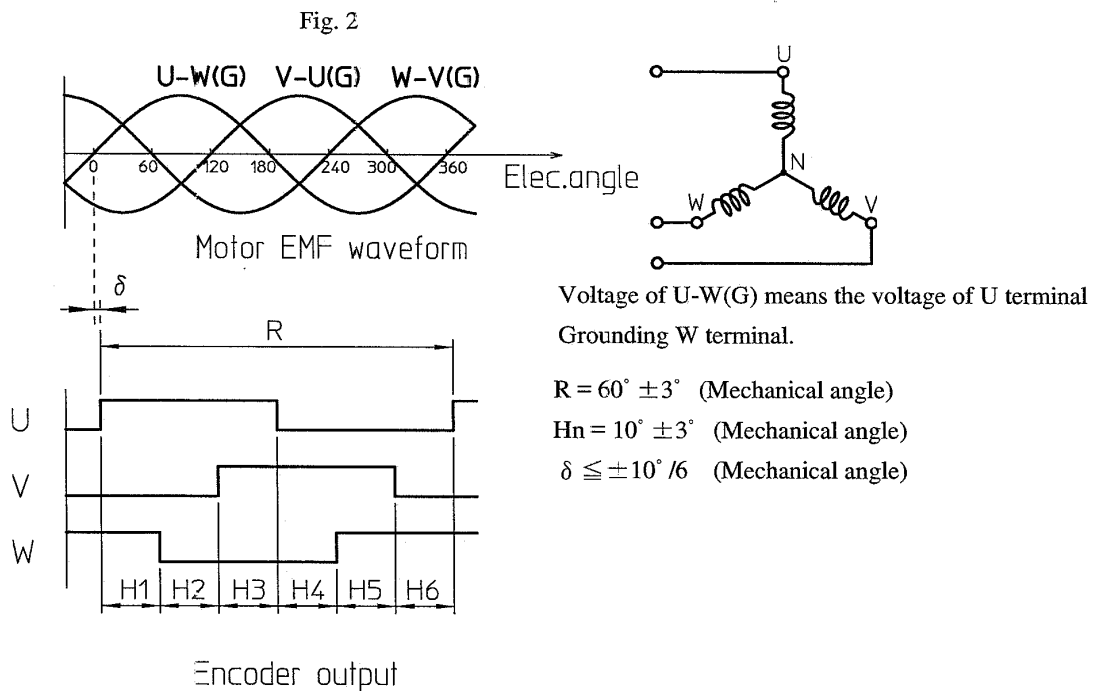

Fig 2 shows U, V and W signal and relationship with motor's EMF with CW rotation facing the encoder end (the end of the actuator output shaft).



						CLASS	SPEC NO.
							B2N1631
REV	DATE	DESCRIPTION	BY	CHKD	APPD	SHEET NO.	4 OF 5

### 4-3 Encoder leads

Color code of encoder leads shown in Table 4

Table 4

Color	Signal	Color	Signal
Red	V <sub>CC</sub>	Black	GND
Green	A	Green/White	$\bar{A}$
Gray	B	Gray/White	$\bar{B}$
Yellow	Z	Yellow/White	$\bar{Z}$
Brown	U	Brown/White	$\bar{U}$
Blue	V	Blue/White	$\bar{V}$
Orange	W	Orange/White	$\bar{W}$

### 4-4 Output circuit and example for receiving signal.

Fig 3 shows output circuit of encoder and example for input circuit to user's device

Fig. 3

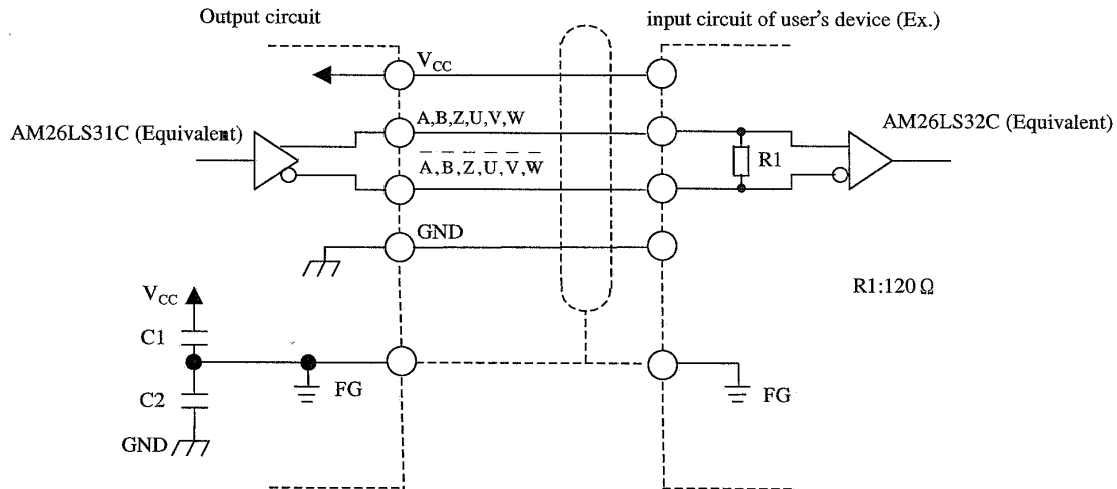

Voltage strength of capacitor C1,C2 : 50V

						CLASS	SPEC NO.
							B2N1631
REV	DATE	DESCRIPTION	BY	CHKD	APPD	SHEET NO.	5 OF 5